



60V Input , 150mA , Low Current Consumption , CMOS LDO

Description

⑥	RoHS2.0
---	---------

The AF76XXH series of low-dropout linear regulators are low quiescent current LDOs with excellent liner and ultra-fast load transient performance. The AF76XXH series is capable of delivering 150mA output current and allow an input voltage as high as 60V.

The series are very suitable for the battery-powered equipment such as RF applications and other systems requiring a quiet voltage source.

Applications

- Wireless Communication tools
- Laptop, Palmtops and PDAs
- Portable AV systems
- Radio control systems
- Car Navigation systems
- Portable Audio Video Equipment

Device Information

AF 76 XX H C/M/P R

- ① ② ③ ④ ⑤ ⑥

①	Standard
②	Product Series
③	Output Voltage e.g. 36 = 3.6V
④	High voltage Input
⑤	C: SOT23-5L Package
	M: SOT23-3L Package
	P: SOT89-3 Package

Features

- Input Voltage Range: 2.5V~60V
- Output Voltage Range: 1.2V~12V
- Output Current: 150mA
- Quiescent Current: 3uA
- Dropout Voltage: 500mV@50mA
- High Accuracy: ±2%/1% (Typ.)
- High PSRR: 80dB at 1kHz
- Excellent Line and Load Transient Response
- Short-Circuit Protection
- Built-in Current Limiter
- Over-Temperature Protection

Typical Application

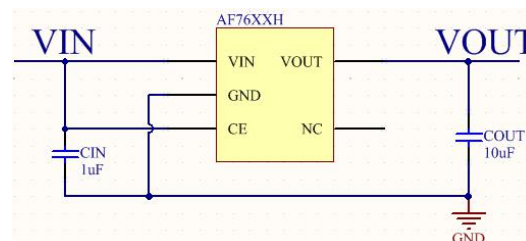

Pin Configuration

Symbol	Package Pin	
	SOT23-5L	SOT89-3L
VIN	1	2
GND	2	1
CE	3	
NC	4	
OUT	5	3

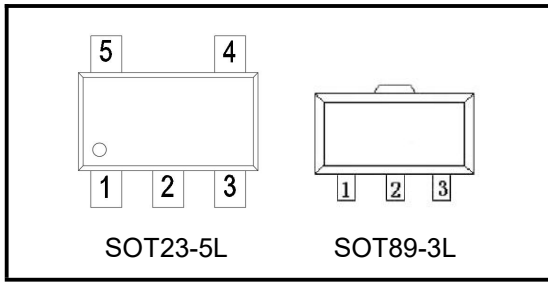

Absolute Maximum Ratings⁽¹⁾

(Unless otherwise specified, all voltages are with respect to GND, T_A=25°C)

PARAMETER		SYMBOL	RATINGS	UNITS
Input Voltage ⁽³⁾		V _{IN}	-0.3~80	V
CE Pin Voltage ⁽³⁾		V _{CE}	-0.3~V _{IN}	V
Output Voltage ⁽³⁾		V _{OUT}	-0.3~15	V
Output Current		I _{OUT}	400	mA
Power Dissipation	SOT89-3	P _D	0.6	W
	SOT23-5		0.4	
Operating Junction Temperature Range		T _J	-40~125	°C
Storage Temperature		T _{STG}	-40~125	°C
Lead Temperature(Soldering, 10 sec)		T _L	260	°C
ESD rating ⁽²⁾	Human Body Model -(HBM)		2	kV
	Machine Model-(MM)		200	V

(1). Stresses beyond those listed under absolute maximum ratings may cause permanent damage to the device. These are stress ratings only, and functional operation of the device at these or any other conditions beyond those indicated under recommended operating conditions is not implied. Exposure to absolute-maximum-rated conditions for extended periods may affect device reliability.

(2). ESD testing is performed according to the respective JESD22 JEDEC standard. The human body model is a 100 pF capacitor discharged through a 1.5kΩ resistor into each pin. The machine model is a 200pF capacitor discharged directly into each pin.

(3). All voltages are with respect to network ground terminal.

Recommended Operating Condition⁽¹⁾

Parameters	Min.	Typ.	Max.	Units
Input Voltage Range	2.5		60	V
Output Current			150	mA
Operating Junction Temperature Range	-40		125	°C
Output Capacitance		10		uF



✚ Electronics Characteristics

(Unless otherwise specified, $V_{IN} = V_{CE} = V_{OUT} + 2V$, $C_{IN} = C_{OUT} = 1\mu F$, $T_A = 25^\circ C$)

PARAMETER	SYMBOL	CONDITIONS	MIN	TYP	MAX	UNIT
Input Voltage	V_{IN}		2.5		60	V
Output Voltage	V_{OUT}	$I_{OUT} = 1mA$	0.98 V_{OUT}	V_{OUT}	1.02 V_{OUT}	V
Dropout Voltage	V_{DIF}	$I_{OUT} = 50mA$		500		mV
Quiescent Current	I_Q	$I_{OUT} = 0$	$V_{OUT} < 5V$	3	6	uA
			$V_{OUT} \geq 5V$	5	10	
Shutdown current	I_{CEL}	$V_{CE} = V_{SS}$		0.1	0.5	uA
Line Regulation	ΔV_{LINE}	$I_{OUT} = 10mA$ $V_{OUT} + 1V \leq V_{IN} \leq 18V$		0.01	0.3	%/V
Load Regulation	ΔV_{LOAD}	$V_{IN} = V_{OUT} + 1V$ $1mA \leq I_{OUT} \leq 100mA$		10		mV
Temperature Coefficient	T_C	$I_{OUT} = 10mA$ $40^\circ C < T_A < 125^\circ C$		50		ppm
Current Limit	I_{LIM}	$V_{OUT} = 0.5 \times V_{OUT}$ $V_{IN} = 5V$	150	250		mA
Short Current	I_{SHORT}	$V_{OUT} = V_{SS}$		20		mA
Accuracy		$I_{OUT} = 10mA$	-2		2	%
Output Noise Voltage	V_{ON}	BW=10Hz to 100kHz		27 x V_{OUT}		μV_{RMS}
Power Supply Rejection Ratio	PSRR	$I_{OUT} = 50mA$	100Hz		75	dB
			1kHz		80	
			10kHz		60	
			100 kHz		45	
Thermal Shutdown Temperature	T_{SD}			170		$^\circ C$
CE "High" Voltage	V_{CEH}		1.5		V_{IN}	V
CE "Low" Voltage	V_{CEL}				0.3	V

✚ Typical Characteristics

(Unless otherwise specified, $V_{IN}=V_{OUT}+1V$, $C_{IN}=C_{OUT}=1\mu F$, $T_A=25^\circ C$)

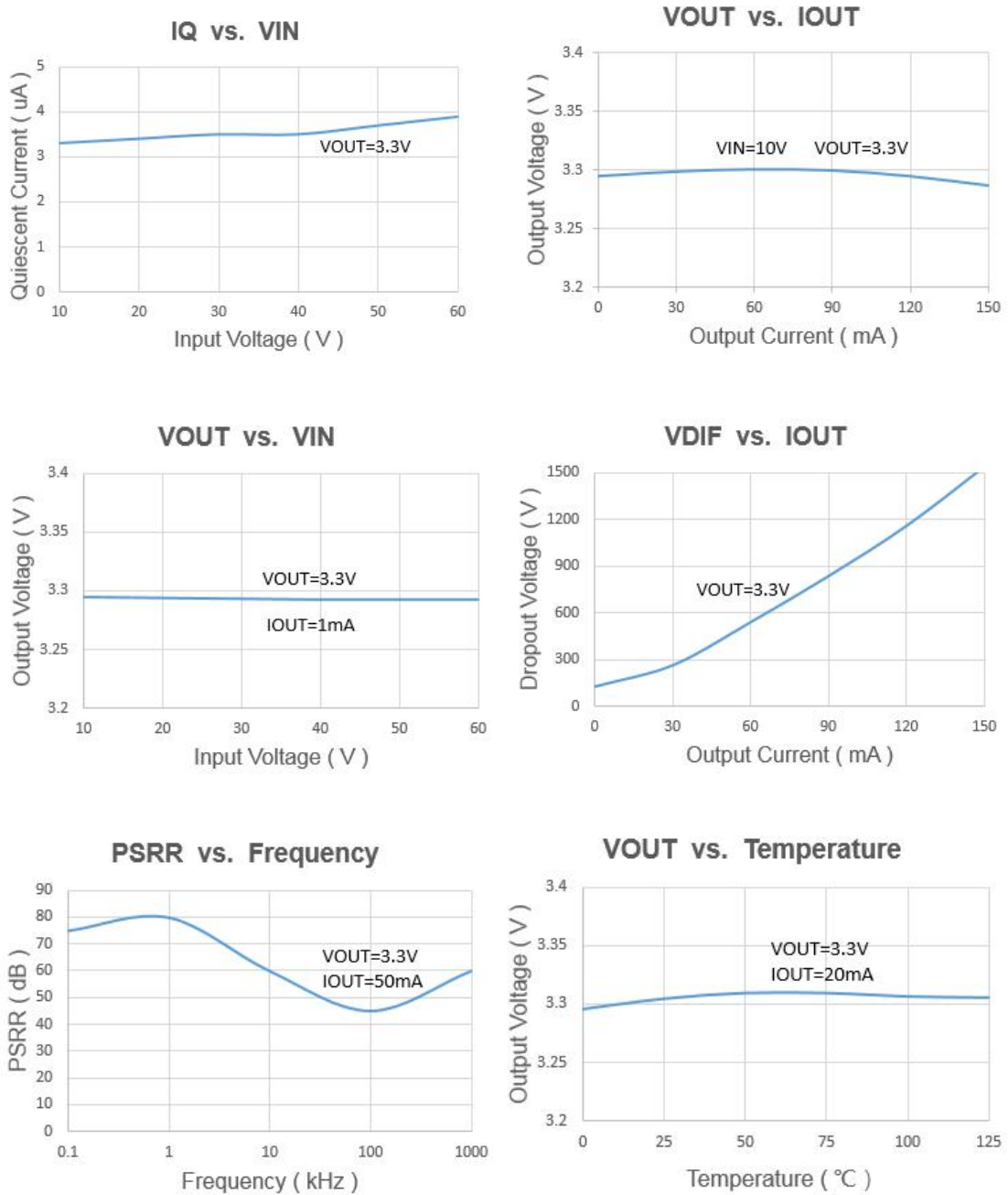

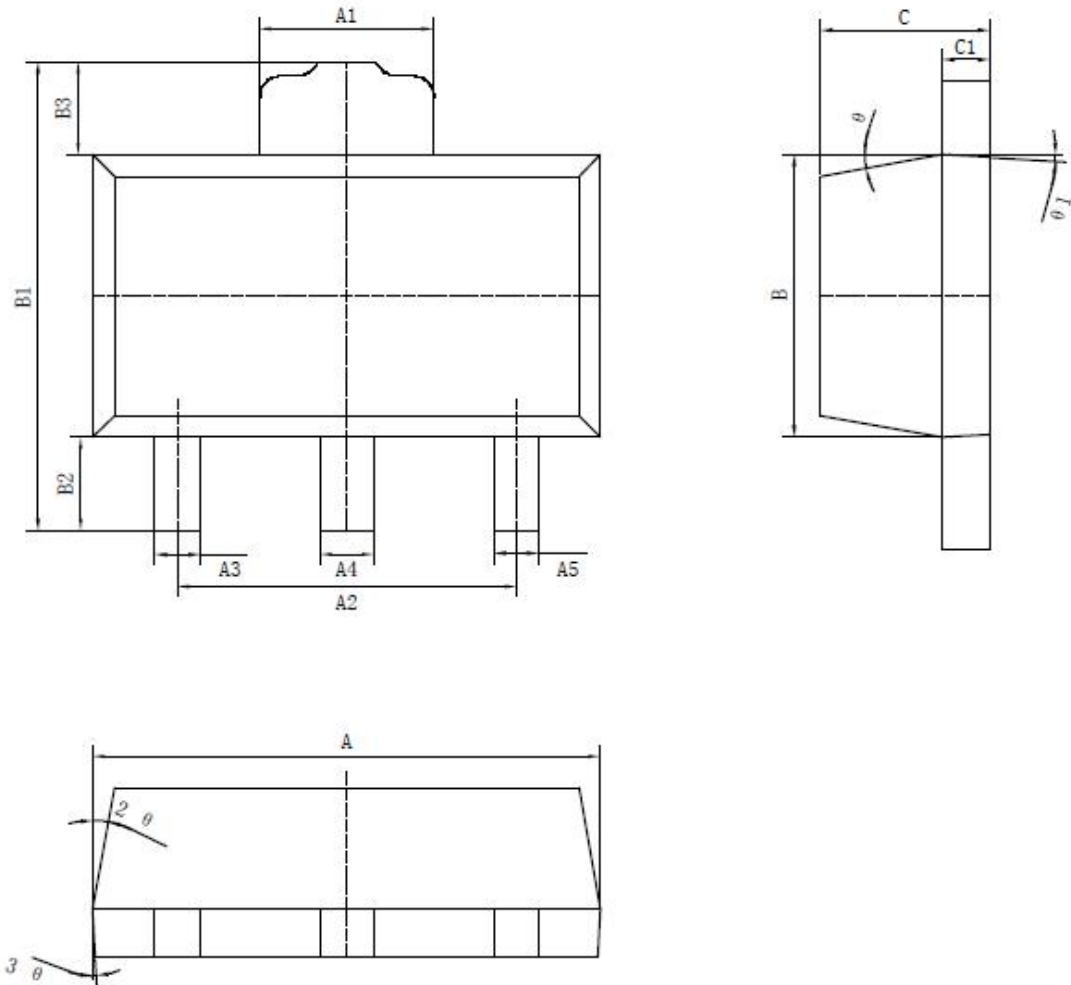
Package Information

标注	尺寸	最小(mm)	最大(mm)	标注	尺寸	最小(mm)	最大(mm)
	A	4.40	4.60		B3	0.82	0.83
	A1	1.65	1.75		C	1.40	1.60
	A2	2.95	3.05		C1	0.35	0.45
	A3	0.35	0.45		θ	6° TYP4	
	A4	0.43	0.53		θ_1	3° TYP4	
	A5	0.35	0.45		θ_2	6° TYP4	
	B	2.40	2.60		θ_3	3° TYP4	
	B1	4.05	4.25				
	B2	0.82	0.83				

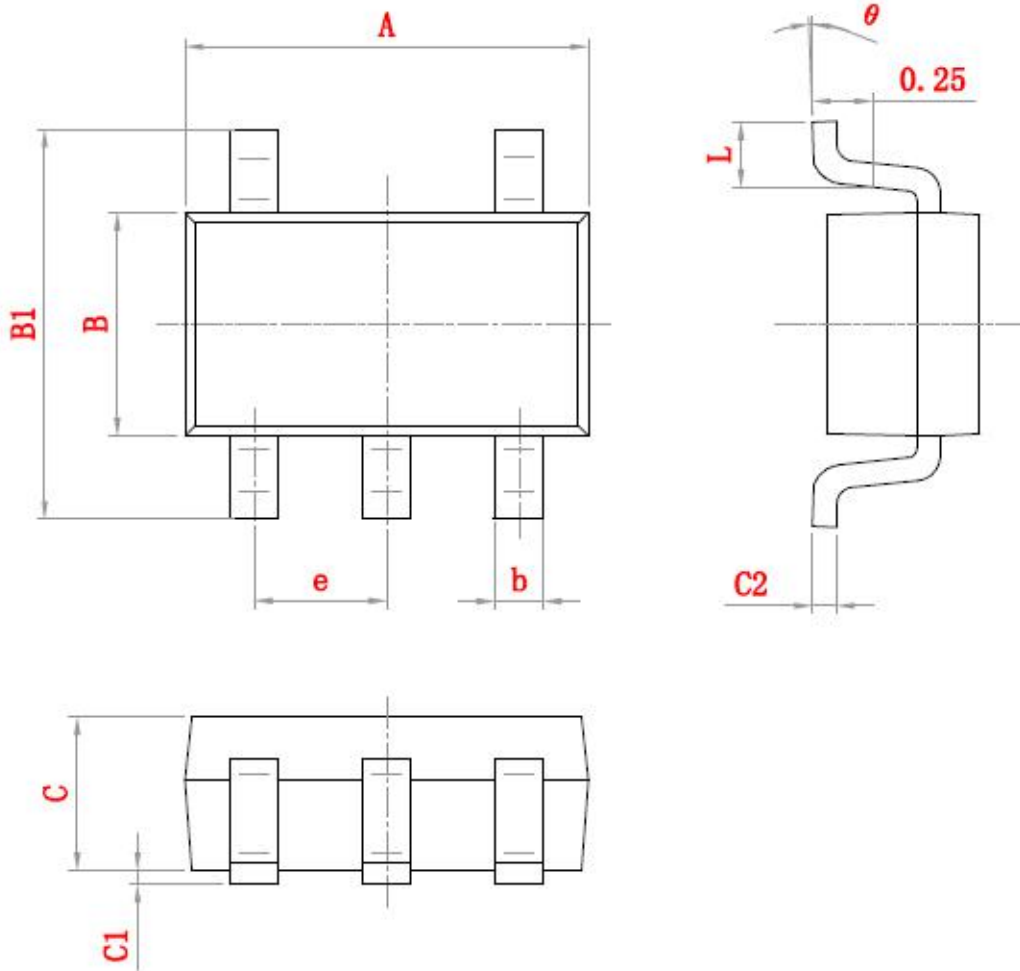

尺寸 标注	最小(mm)	最大(mm)	尺寸 标注	最小(mm)	最大(mm)
A	2.82	3.02	C	1.05	1.15
e	0.95 (BSC)		C1	0.03	0.15
b	0.28	0.45	C2	0.12	0.23
B	1.50	1.70	L	0.35	0.55
B1	2.60	3.00	θ	0°	8°



 **Order Information**

Voltage	SOT23-5	Marking	Shipping	SOT89-3	Marking	Shipping
1.2			Tape and Reel, 3K			Tape and Reel, 1K
1.5						
1.8						
3.3	√	7633H				
3.6						
5.0					√	

DISCLAIMER

AFSEMI RESERVES THE RIGHT TO MAKE CHANGES WITHOUT FURTHER NOTICE TO ANY PRODUCTS HEREIN TO IMPROVE RELIABILITY, FUNCTION OR DESIGN. AFSEMI DOES NOT ASSUME ANY LIABILITY ARISING OUT OF THE APPLICATION OR USE OF ANY PRODUCT OR CIRCUIT DESCRIBED HEREIN; NEITHER DOES IT CONVEY ANY LICENCE UNDER ITS PATENT RIGHTS, NOR THE RIGHTS OF OTHERS.

THE GRAPHS PROVIDED IN THIS DOCUMENT ARE STATISTICAL SUMMARIES BASED ON A LIMITED NUMBER OF SAMPLES AND ARE PROVIDED FOR INFORMATIONAL PURPOSE ONLY. THE PERFORMANCE CHARACTERISTICS LISTED IN THEM ARE NOT TESTED OR GUARANTEED. IN SOME GRAPHS, THE DATA PRESENTED MAY BE OUTSIDE THE SPECIFIED OPERATING RANGE (E.G. OUTSIDE SPECIFIED POWER SUPPLY RANGE) AND THEREFORE OUTSIDE THE WARRANTED RANGE.