

Over voltage and over current protection IC

Description

AF4806 is an Over-Voltage-Protection (OVP) IC. The device will switch off internal MOSFET to disconnect VIN to OUT to protect load when any of input voltage, input current over the threshold. The Over temperature protection (OTP) function monitors chip temperature to protect the device.

Applications

- PND
- Tablet
- HD Player
- OTT
- Digital Cameras
- Digital Videos

Device Information

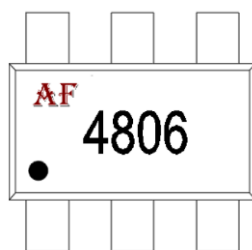

Marking

Top view

Package	Tape and Reel
SOT23-6L	3000 pcs

Features

- High voltage technology
- Maximum input voltage :30V
- Output power ON time :8ms(Typ)
- OVP threshold: 6.1V
- OVP response time :<1us
- Output auto discharge

Typical Application

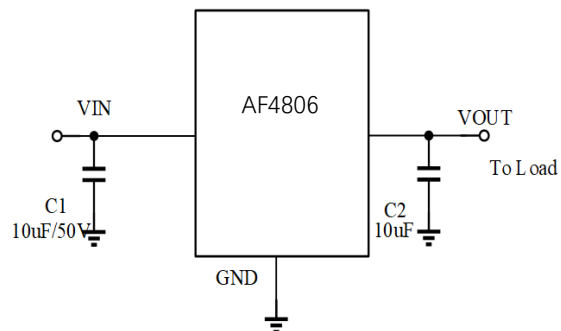

Functional Block Diagram

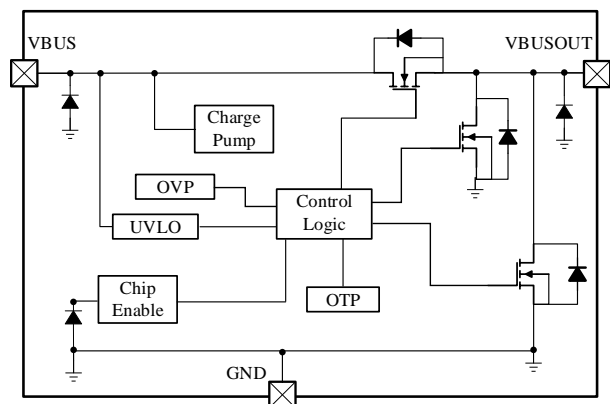

Pin Configuration

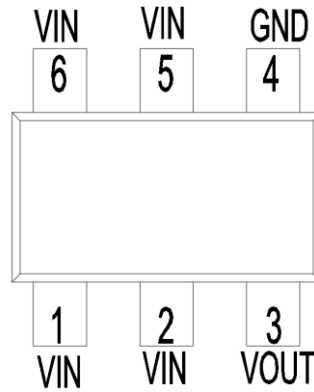

Pin configuration (Top view)

NO.	Symbol	Description
1	VIN	Input pin. A 10uF low ESR ceramic capacitor or larger must be connected as close as to this pin. It is recommended to use 50V capacitor or according to application.
2	VIN	
3	VOUT	Output pin, Connect to load.
4	GND	Ground
5	VIN	Input pin. A 10uF low ESR ceramic capacitor or larger must be connected as close as to this pin. It is recommended to use 50V capacitor or according to application.
6	VIN	

Absolute Maximum Ratings⁽¹⁾

(Unless otherwise specified, all voltage are with respect to GND, TA=25°C)

PARAMETER	SYMBOL	RATINGS	UNITS
Input voltage (ACIN pin)	V _{IN}	-0.3 ~ 30	V
Output voltage (VOUT pin)	V _{OUT}	-0.3 ~ 30	V
Junction temperature	T _J	150	°C
Storage temperature	T _{stg}	-55 ~ 150	°C
ESD Ratings	HBM	±3000	V
	MM	±200	V

(1). Stresses beyond those listed under absolute maximum ratings may cause permanent damage to the device. These are stress ratings only, and functional operation of the device at these or any other conditions beyond those indicated under recommended operating conditions is not implied. Exposure to absolute-maximum-rated conditions for extended periods may affect device reliability.

Recommend Operating Conditions

(Ta=25°C, unless otherwise noted)

Parameter	Symbol	Value	Unit
Input voltage	V _{IN}	3.5 ~ 30	V
Output current	I _{OUT}	3	A
Ambient operating temperature	T _{opr}	-40 ~ 85	°C

Electrical Characteristics

(Ta=25°C, unless otherwise noted)

Parameter	Symbol	Test conditions	Min	Typ	Max	Unit
DC characteristics and Power-ON-Reset						
Input quiescent current	I _Q	V _{ACIN} =5V, I _{out} =0A		120	200	uA
IN-to-OUT ON resistance	R _{ON}	V _{ACIN} =5V, I _{out} =3A		30		mΩ
Output auto discharge resistance	R _{DISCHARGE}			500		Ω
Under voltage lock out threshold	UVLO	V _{ACIN} increasing from 0~3.5V		3.4		V
Under voltage lock out hysteresis	V _{HYS-UVLO}	V _{ACIN} decreasing from 3.5~0V		300		mV
Output power-on time	T _{ON}	V _{ACIN} =0 -> 5V to output ON	6	8	12	ms
EN Threshold Voltage	VENL				0.4	V
	VENH		1.2			V
EN to GND current	I _{EN}				2	uA
Input Over-Voltage-Protection (OVP)						
PROADJ threshold	V _{OVP(th)}	V _{ACIN} increasing from 5~7V	5.7	6.1	6.3	v
PROADJ hysteresis	V _{HYS-PROADJ}	V _{ACIN} decreasing from 7~5V		70		mV
OVP active time	T _{OVP}	V _{ACIN} = 5 -> 10V			1	us
OVP recovery time	T _{ON(OVP)}	V _{ACIN} =10 -> 5V to output ON	6	8	10	ms
Over-Temperature-Protection (OTP)						
OTP threshold	T _{OTP}			155		°C
OTP hysteresis	T _{OTPHYS}			40		°C
Power Switch Body Diode						
Forward peak surge current	I _{FSM}	Pulse Width=10ms			15	A
		Pulse Width=20us			50	A

Typical characteristic

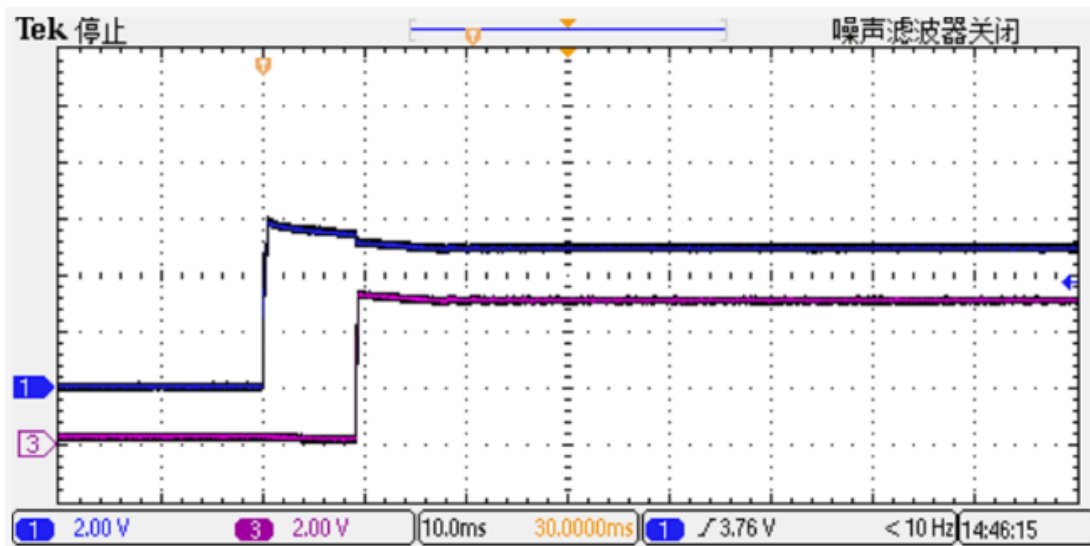

Power On

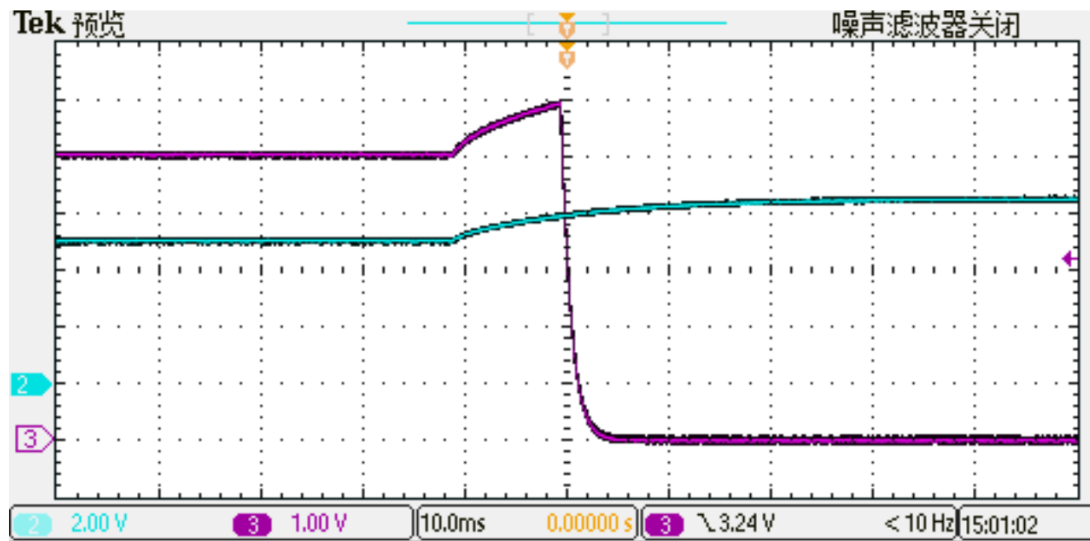

OVP Trigger

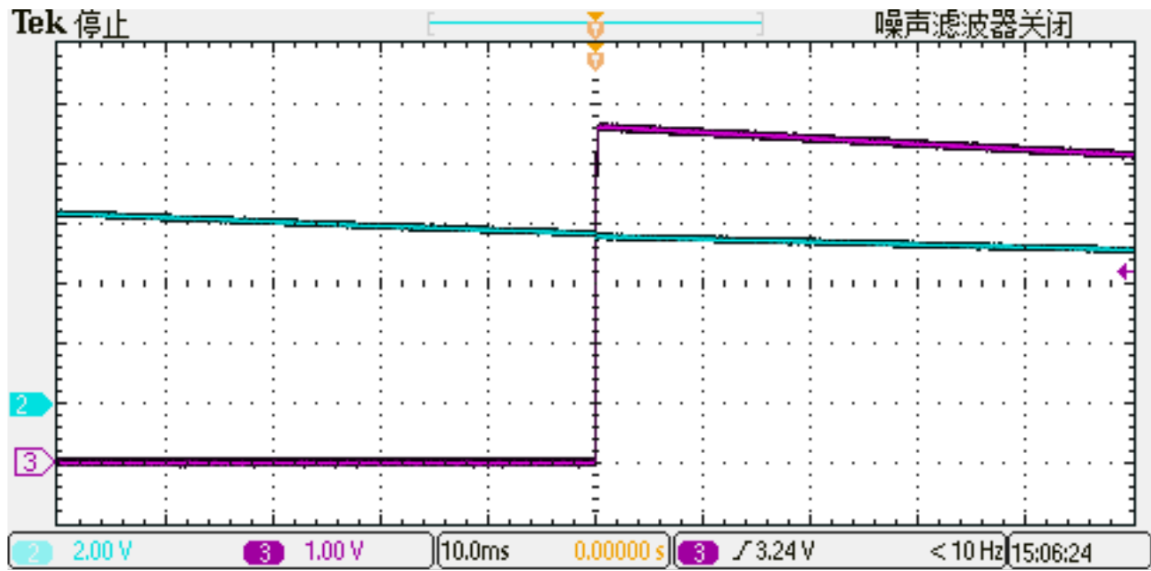

OVP Restore

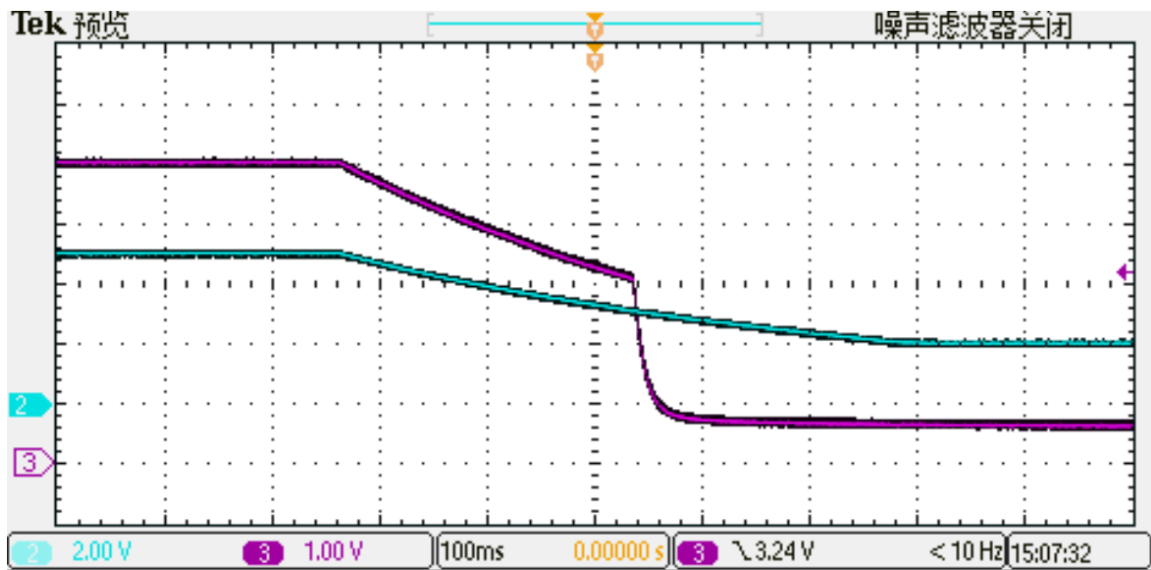

UVLO Trigger

Package Outline

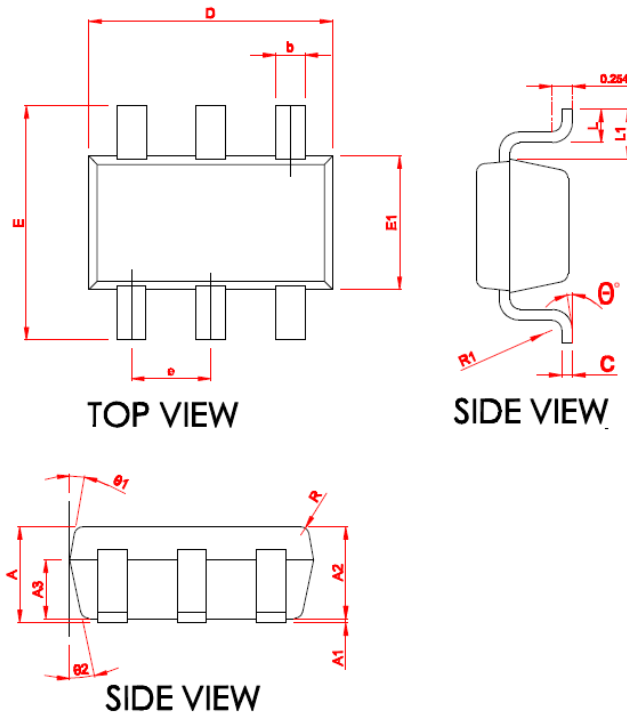

SYMBOL	MILLIMETER		
	MIN	NOM	MAX
A	1.06	1.15	1.24
* A1	0.01	0.05	0.09
* A2	1.05	1.10	1.15
A3	0.65	0.70	0.75
* b	0.30	0.35	0.45
* c	0.117	0.127	0.157
* D	2.87	2.92	2.97
* E	2.72	2.80	2.88
* E1	1.55	1.60	1.65
* e	0.90	0.95	1.00
* L	0.32	0.40	0.48
* L1	0.55	0.60	0.65
R	0.10 REF		
R1	0.12 REF		
* θ	0	—	8°
θ_1	8°	10°	12°
θ_2	10°	12°	14°

DISCLAIMER

AFSEMI RESERVES THE RIGHT TO MAKE CHANGES WITHOUT FURTHER NOTICE TO ANY PRODUCTS HEREIN TO IMPROVE RELIABILITY, FUNCTION OR DESIGN. AFSEMI DOES NOT ASSUME ANY LIABILITY ARISING OUT OF THE APPLICATION OR USE OF ANY PRODUCT OR CIRCUIT DESCRIBED HEREIN; NEITHER DOES IT CONVEY ANY LICENCE UNDER ITS PATENT RIGHTS, NOR THE RIGHTS OF OTHERS.

THE GRAPHS PROVIDED IN THIS DOCUMENT ARE STATISTICAL SUMMARIES BASED ON A LIMITED NUMBER OF SAMPLES AND ARE PROVIDED FOR INFORMATIONAL PURPOSE ONLY. THE PERFORMANCE CHARACTERISTICS LISTED IN THEM ARE NOT TESTED OR GUARANTEED. IN SOME GRAPHS, THE DATA PRESENTED MAY BE OUTSIDE THE SPECIFIED OPERATING RANGE (E.G. OUTSIDE SPECIFIED POWER SUPPLY RANGE) AND THEREFORE OUTSIDE THE WARRANTED RANGE.